

W I C K L O W

ENDLESS OPPORTUNITIES

WICKLOW COUNTY COUNCIL  
PLANNING AND DEVELOPMENTS ACTS 2000  
(AS AMENDED) & PLANNING & DEVELOPMENTS REGULATIONS 2001 (AS AMENDED)

## PROPOSED DEVELOPMENT

### BLUEWAY PROJECT – GREYSTONES SOUTH BEACH BOARDWALK

#### Description

A boardwalk extending from the South Beach Promenade out onto the strand and then along it would provide universal access to the beach. The South Beach Promenade is connected to the Greystones town footpath network and has disabled parking bays at either end as well as the train station and bus stops within 250m of the promenade.

#### Specification

The boardwalk is to be approximately 150m long and circa 3m wide. The boardwalk is to be secured to the beach and supported by recycled plastic posts. The posts are to be a minimum of 100mmx100mm in section and should be driven circa 1200mm into the sand. The boardwalk should have a load bearing capacity of 5kn/m<sup>2</sup>. The boardwalk shall have a 150mm upstand along the edges. Boards shall be placed with 10mm gaps between boards and no more than 12mm. All fixings should be of stainless steel.

# BOARDWALK WITH BALUSTRADE



\* dimensions in mm

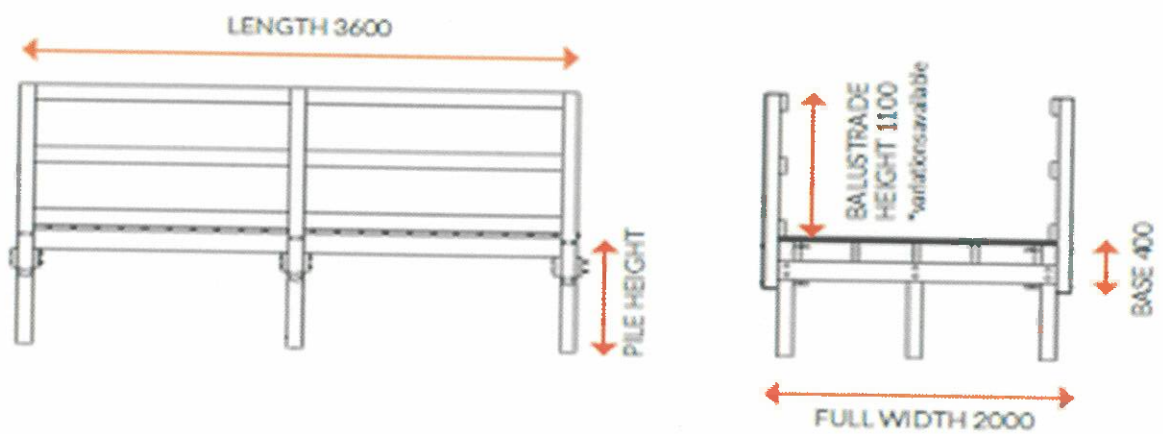



**Figure 1: Works location on South Beach**



**Figure 2: Site Location**